

CLASS "A" TOWER DETAIL

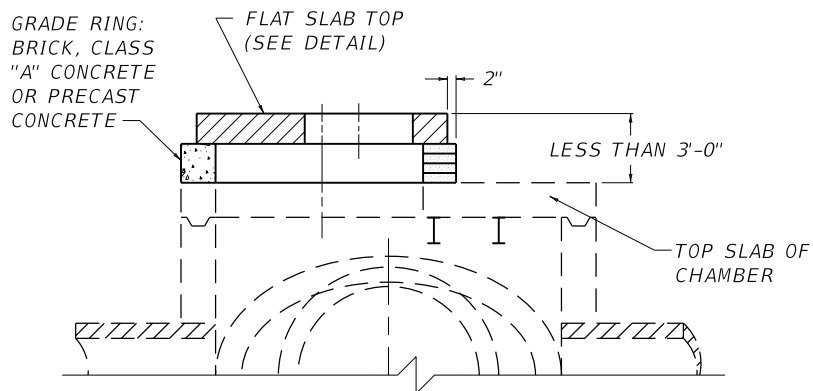

CLASS "B" TOWER DETAIL

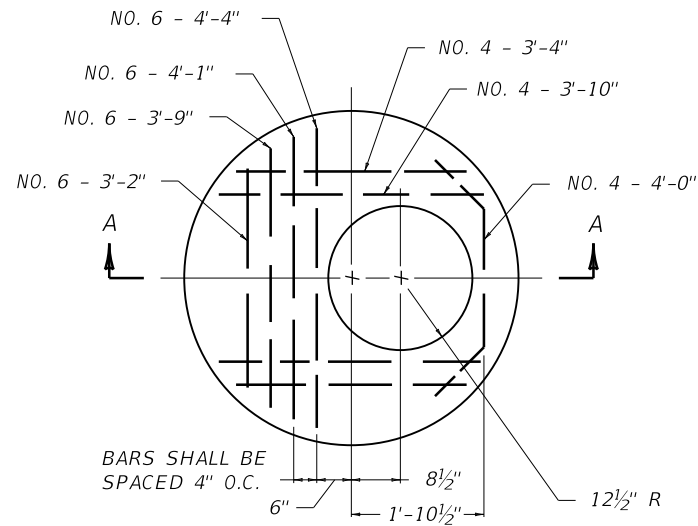

PLAN VIEW  
FLAT SLAB TOP DETAIL

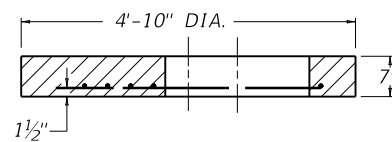

SECTION A-A  
FLAT SLAB TOP DETAIL

USE WITH CUR. STD. DWGS.  
RDM-010 RDM-012 RDM-013

KENTUCKY  
DEPARTMENT OF HIGHWAYS

MANHOLE TYPE C  
(TOWER APPLICATIONS)

STANDARD DRAWING NO. RDM-011-05

SUBMITTED	<i>[Signature]</i>	12-01-15
DESIGNED BY	DATE OF DESIGN	DATE
APPROVED	<i>[Signature]</i>	12-01-15
	STATE HIGHWAY ENGINEER	DATE